

Unit 5 Lesson 10: Cross Sections and Volume

1 Two Stacks of Coins (Warm up)

Student Task Statement

The images show the same number of coins arranged in different ways.

A



B



1. How are the two coin stacks different from each other?
2. Does either stack of coins resemble a geometric solid? If so, which stack and what solid?
3. How do the heights of the two stacks compare?
4. How do the volumes of the two stacks compare? Explain your reasoning.

2 Rectangular Prism, Shifted

Student Task Statement

The image shows two rectangular prisms. The bases of the prisms are congruent. Each base has area B square units, and the prisms are the same height. A plane intersects the two prisms parallel to their bases, creating cross sections.

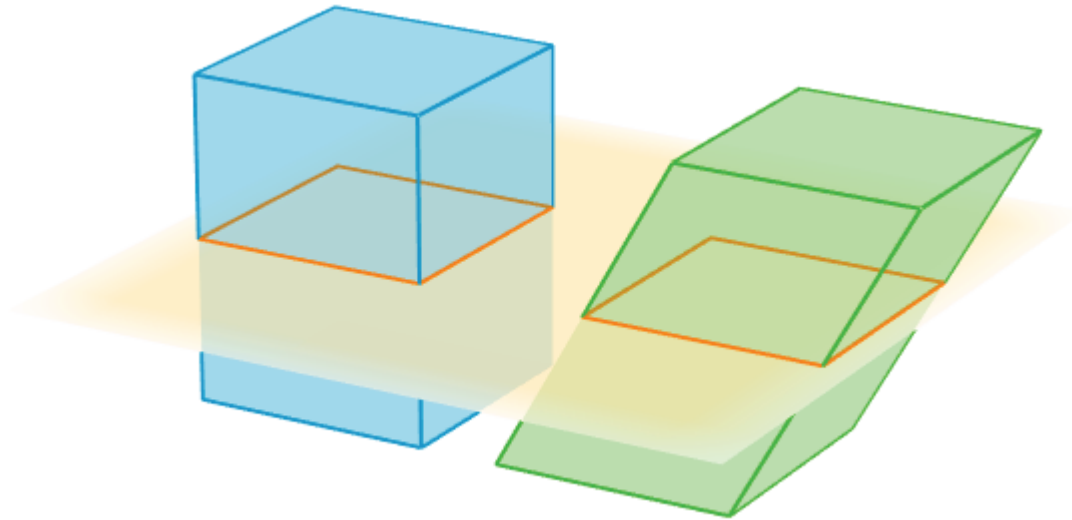

1. Sketch the two cross sections. How do their shapes and areas compare to each other?
2. How would the shape or area of the cross sections change if we moved the plane up or down?
3. How do the volumes of the two prisms compare? Explain your reasoning.

Activity Synthesis

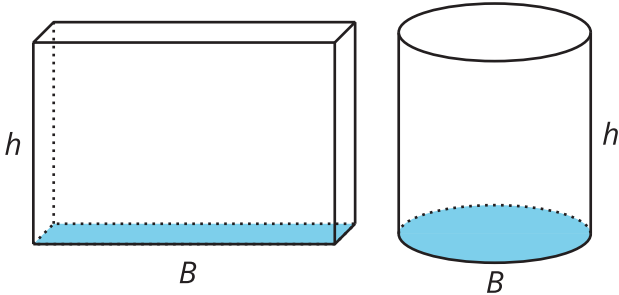

3 Equal Volumes?

Student Task Statement

For each pair of solids, decide whether the volumes of the two solids are equal. Explain your reasoning. If you and your partner disagree, discuss each other's approach until you reach agreement.

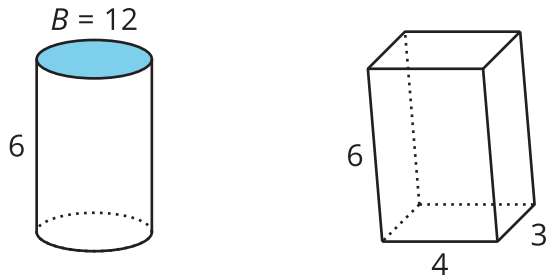

1.

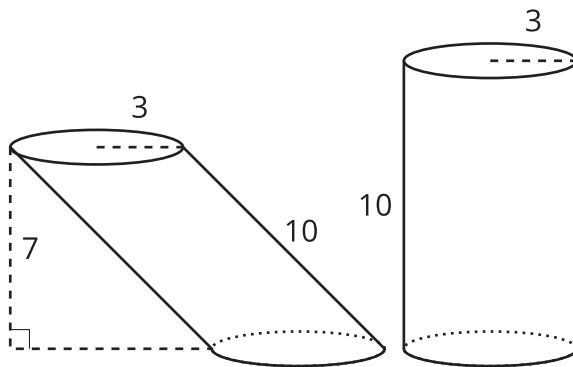

2.

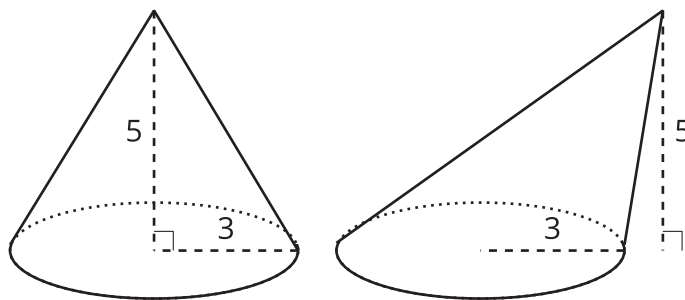

3.

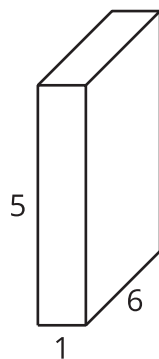
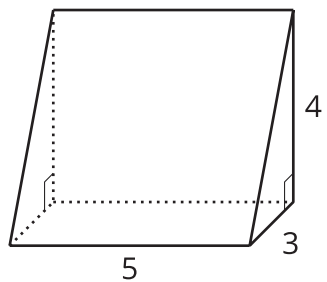

4.

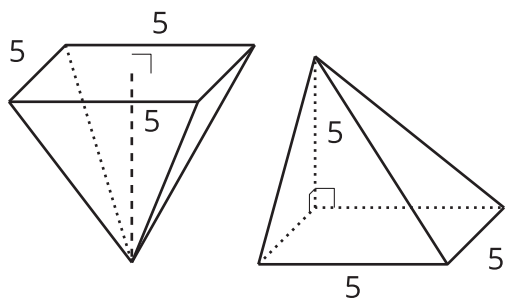

5.

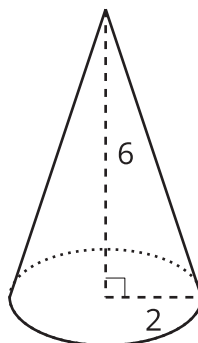
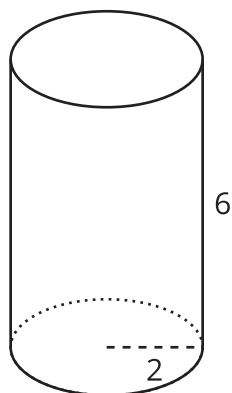

6.

Images for Activity Synthesis

