

# Family Support Materials

## Finding Volume

In this unit, students find the volume of rectangular prisms and figures composed of two prisms.

### Section A: Unit Cubes and Volume

In this section, students learn to call the amount of space an object takes up **volume**. Volume is measured in cubes. For example, this prism has a volume of 120 cubes.

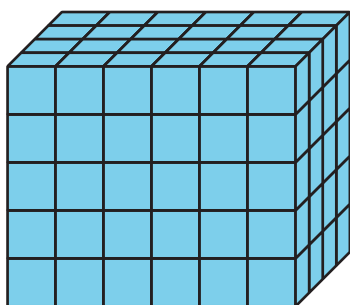

To find the volume of any prism, students can find the number of cubes in one layer and multiply that number by the number of layers. In this example, students might describe this prism as having 5 layers of 24 cubes.

They can find the number of cubes by multiplying 5 and 24. So,  $5 \times 24 = 120$ .

### Section B: Expressions for Finding Volume

In this section, students find the volume of a rectangular prism by multiplying the side lengths or by multiplying the area of the base by the height.

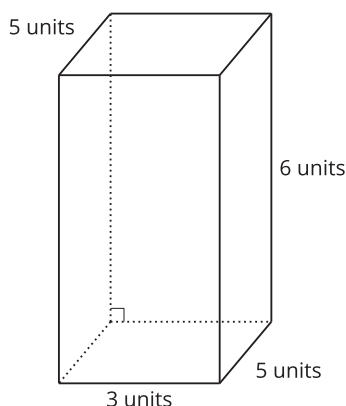

For example they can multiply the length by width by height, or  $3 \times 5 \times 6$  or they can find the bottom area by multiplying  $3 \times 5$  to get 15 and then multiplying 15 by 6. The volume of this rectangular prism is 90 cubic units.

### Section C: Volume of Solid Figures

In this section, students learn that some figures are made from two rectangular prisms. They break apart these figures and find the volume of each prism. Then, they add the volumes of the two prisms to find the total volume of the figure.

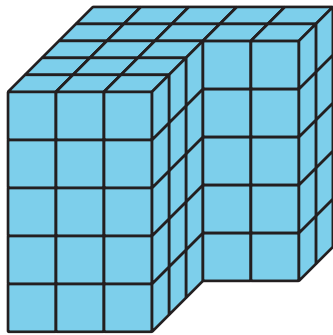

Depending on how they break it apart, they can find the volume in different ways. They could multiply in these ways to find the volume of the figure:

$$(3 \times 3 \times 5) + (5 \times 2 \times 5)$$

$$(3 \times 5 \times 5) + (2 \times 2 \times 5)$$

## Try it at home!

Near the end of the unit, find the volume of these figures with your student.

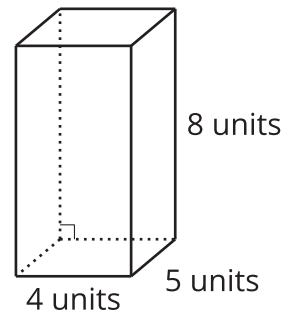
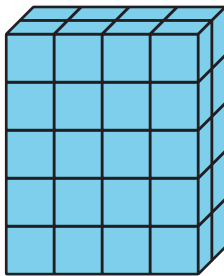

Questions that may be helpful as they work:

- How are the 2 problems the same? How are they different?
- Can you explain or show me how you found the volume?
- How did you know you needed that number or piece of information?